

ROBINAIR

Operating Manual

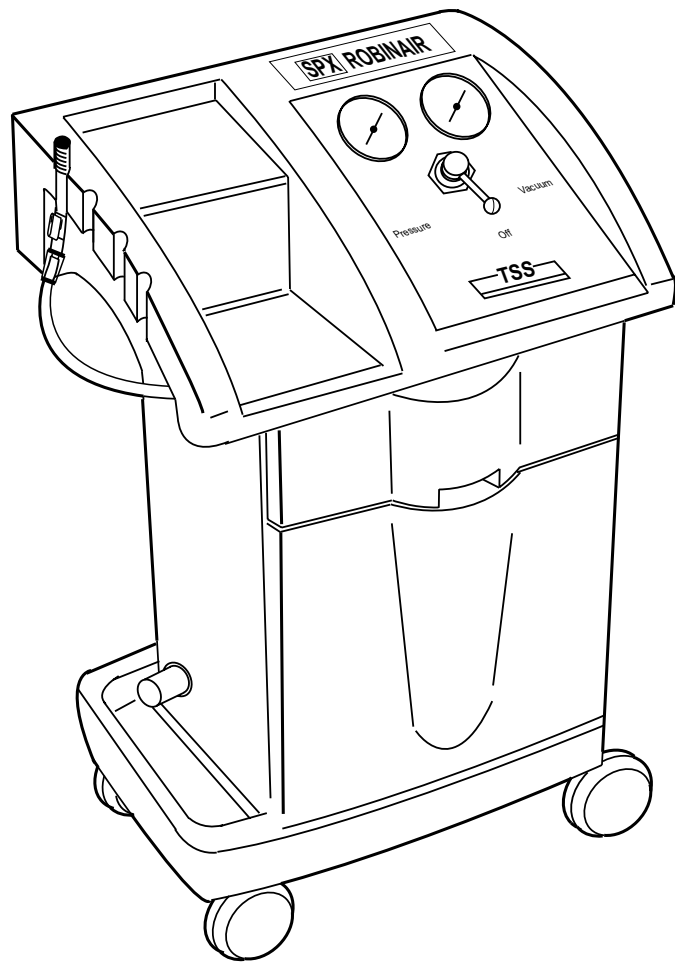

Model 82000
Transmission Service Solution

Safety Precautions

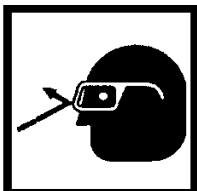

This equipment should only be operated by qualified service personnel familiar with vehicle operation and systems. Observe the following safety precautions to reduce the risk of fire and personal injury.

- Read and follow operating instructions and safety precautions before using the TSS Transmission Service Solutions Model 82000. Refer to the Material Safety Data Sheet supplied with the cleaning solution for more specific safety information.
- Wear eye protection that meets OSHA requirements and ANSI Z87.1 standards. If eye contamination occurs, flush eyes with water for 15 minutes. Seek medical attention.
- Wear standard industrial rubber gloves. Do not let solution touch skin. If skin contamination occurs, remove contaminated clothing and launder separately. Wash affected skin with soap and water.
- If solution is swallowed, seek medical attention immediately. Do NOT induce vomiting. Vomiting can lead to pneumonitis, which can be fatal. Have the victim lie down and keep warm while waiting for a physician.
- Solution containers can explode if exposed to extreme heat (about 49°C/120°F). Store solutions away from heat and open flames.
- Keep test area well ventilated. Engines produce odorless carbon monoxide, which causes slower reaction time and can lead to serious injury. Attach vehicle exhaust system to an exhaust disposal system. If high vapor exposure occurs, move victim to fresh air. If victim is having difficulty breathing, seek medical attention immediately. If victim stops breathing, give artificial respiration and seek medical attention immediately.
- Keep hands, hair, loose clothing and jewelry away from the battery, fan blades, belts, and other moving parts.
- Tighten all connections before cleaning; leakage could cause a fire.
- Release system pressure before servicing system components. Open lines carefully because many systems maintain residual pressure after the engine has been shut off. Wrap a clean shop cloth around fittings when connecting or disconnecting hoses and adapters. Clean up spills immediately. Keep lines away from hot manifolds and moving components.
- Observe normal precautions for working with flammable liquids. No smoking, open flames, or electrical sparks. Keep a Class B fire extinguisher nearby.
- Dispose of shop cloths, empty containers, and used fluids according to local, state, and federal health, safety, and pollution laws. Direct questions to appropriate agencies.
- Do not modify any components of the Transmission Service Solution Model 82000. Do not replace any components except those specified by the manufacturer.
- Use only clean, dry shop air, regulated to 100-150 psi.

Technology developed by **Enginewity**®.

Table of Contents

Safety Precautions	2
Guide lines	3
Evaluate the Transmission before Service	3
Introduction	4
Procedures	5
Cleaning Procedure	5
Drain Procedure	7
Depressurizing Procedure	7
Maintenance	8
Function Test	8
Replacement Parts List	9
Flow Diagram.....	10
Warranty	11

Evaluate The Transmission Before Service

It is important to evaluate a car prior to servicing a transmission. Transmissions used under extreme driving conditions or with high mileage may be unsuitable for this transmission cleaning service. The transmission cleaning solution removes contaminants, fibers and varnish. An unsuitable transmission may lose functionality due to buildup on worn parts and seals being removed by the cleaning solution.

Evaluation should include but is not limited to:

- Test drive vehicle for shifting through all gears including reverse without slippage
- Has transmission ever been serviced
- More than 60,000 miles on the odometer
- Vehicle driven under extreme conditions (consult owner's manual for definition of conditions)
- Inspection of transmission fluid on dipstick (clutch fibers, metal particles or shavings)

If the transmission shows signs of excessive wear, particles or you believe the transmission is suspect, inform the customer of the possibility of a transmission failure after service. Allow customer to make the decision to proceed with the transmission cleaning.

SPX Corporation, Robinair is not responsible for any transmission failure that occurs after the Transmission Service Solution process. See Warranty.

Transmission Cleaning Solution

The Transmission Cleaning Solution is designed to be used only with the Transmission Service Solution Model 82000. It is designed to remove varnish and other contaminants on the transmission and accumulator valves to make your vehicle shift more smoothly and give your transmission longer life. At the same time, the Transmission Cleaning Solution rehydrates the seals to help restore internal pressures.

The TSS is powered by regular shop air and there are no moving parts to wear out. The unit must be connected to a shop air source to operate.

The key to this unit's effectiveness is the unique cleaning solution. The solution comes in single application bottles and creates no waste. One 16 oz. bottle will do one cleaning process. The Transmission Cleaning Solution is available in a case of (12) 16 oz. bottles.

Refer to the Material Safety Data Sheet supplied with the cleaning solution for specific safety information. The empty containers are recyclable where facilities exist.

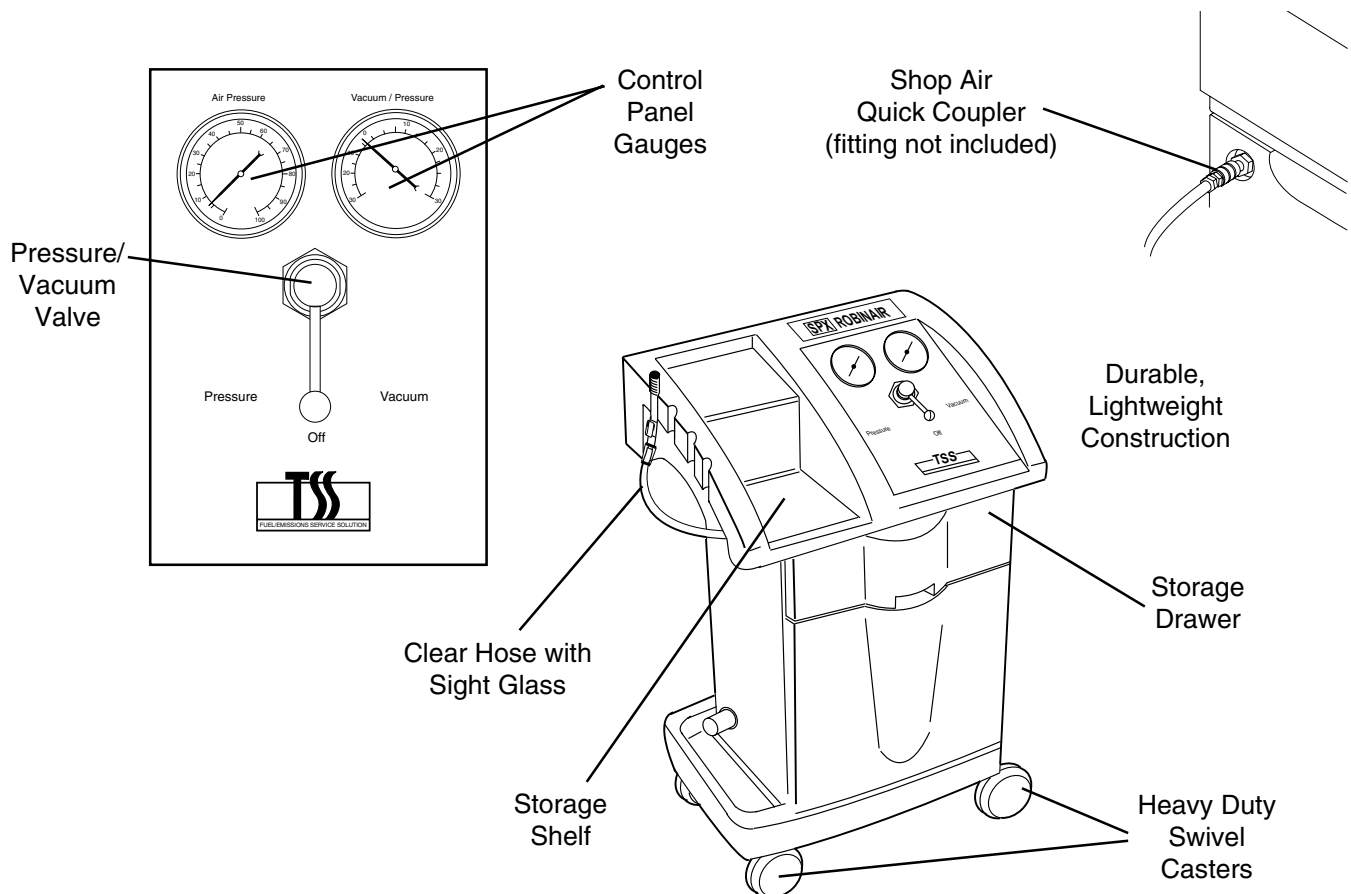

Cleaning Procedure

1. Read, understand and follow the Safety Precautions in this manual before using the TSS.
 2. Verify that the control panel valve is **OFF**.
 3. Connect shop air to the back of the TSS unit. You will need to supply the necessary ¼" male fitting.
 4. Attach the small tube with fitting included with the unit to the hose on the TSS.
 5. Remove and set aside the transmission level indicator (dipstick) from the vehicle.
 6. Insert the hose assembly into the transmission fill tube until the hose hits the bottom of the pan.
 7. Turn the control panel valve on the TSS to **VACUUM**. Remove **just** enough transmission fluid to make room for 1 quart of the Transmission Cleaning Solution. The entire length of the clear hose is approximately 1 quart.
 8. Turn the valve to **OFF**.
 9. Remove the hose assembly from the transmission fill tube.
 10. Add 1 quart of the Transmission Cleaning Solution to the transmission. Do not overfill.
 11. Install the transmission level indicator securely.
 12. Start the engine and drive the vehicle. Allow the vehicle to shift through all the forward and reverse gears. This will allow the cleaning solution to circulate through the accumulator, torque converter and all the cooling lines. Park the vehicle and turn the engine off.
 13. Remove the transmission level indicator and insert the hose assembly to the bottom of the transmission pan.
 14. Turn the control panel valve on the TSS to **VACUUM**. Remove all the fluid from the transmission pan. The pan can be removed at this time and the filter changed per the manufacturer's specifications in the vehicle's service manual. Be sure it is reinstalled securely.
 15. Determine the best place on the cooler line to disconnect.
 16. Connect the hose assembly to the cooler line. Turn the control panel valve to **VACUUM**. After removing all the fluid, connect to the other side of the cooler line.
- NOTE:** The side of the cooler line with the most fluid flow is the pressure side. There is a noticeable difference in flow from the pressure side.
17. With the hose connected to the pressure side of the cooler line, add 4-5 quarts of transmission fluid into the transmission fill tube.

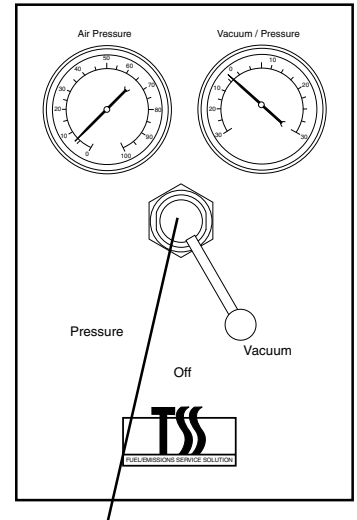

Pressure/
Vacuum
Valve

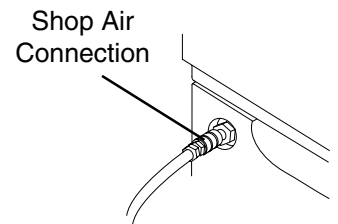

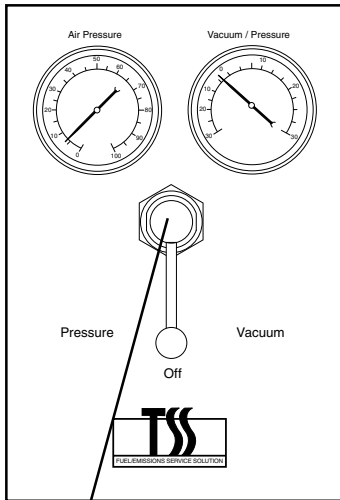

Pressure/
Vacuum
Valve

Cleaning Procedure (continued)

18. Be sure the control panel valve is OFF.
19. With the flow control valve on the hose open (parallel to the hose), start the vehicle and allow to idle.
20. Observe the fluid flow through the hose. Turn off the vehicle as soon as the flow stops or starts to surge. This clears the torque convertor of used transmission fluid.
21. Disconnect the TSS hose from the cooler line. Reattach cooler line on vehicle.
18. Verify the amount of transmission fluid required by the manufacturer's specifications for this vehicle.
19. Remove the level indicator and add enough new transmission fluid to fill the pan.
20. Start the engine and using the transmission level indicator, fill the transmission to the required level. Do not overfill.

Drain Procedure

The TSS unit must be drained of used transmission fluid after **EVERY** job. This requires only a few minutes. Use the following procedure.

1. Place the hose into a receptacle large enough to hold the used transmission fluid.
2. Turn the control panel valve **PRESSURE**.
3. After removing all the fluid from the TSS unit, dispose of properly following all the local and state regulations.
4. Wipe off the TSS unit and store hoses correctly.

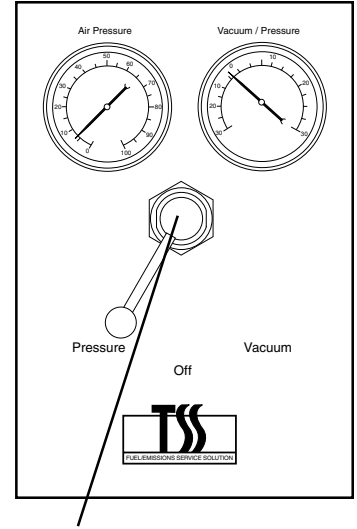

Pressure/
Vacuum
Valve

Depressurizing Procedure

1. Disconnect the shop air source from the TSS.
2. Turn the control panel valve to **PRESSURE**.
3. Slowly open service hose into an approved used fluid container.
4. Turn control panel valve to **OFF**.

NOTE: Internal lines will contain residual transmission fluid.

Disconnect
Shop Air
Source

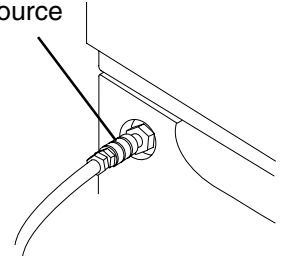

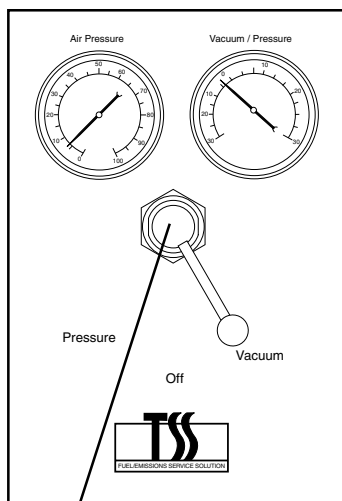

Pressure/
Vacuum
Valve

Connect
Shop Air
Source

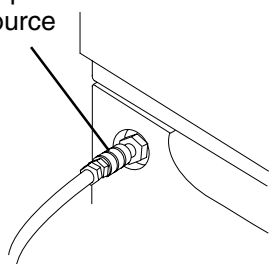

Function Test

1. Connect the shop air source to the back of the TSS.
2. Fill a clean 1 gallon or larger container $\frac{1}{4}$ full with new or used transmission fluid.
3. Attach an adapter to the clear hose of the TSS and place it into the fluid in the container.
4. Move the control panel valve to VACUUM.
5. Open the valve on the clear hose. The transmission fluid in the container will move up the hose and into the unit.
6. When the fluid has all been taken into the unit, turn the control panel valve to OFF.
7. Close the valve on the clear hose.
8. With the hose still in the container, turn the control panel valve to PRESSURE.
9. Open the valve on the clear hose.
10. The fluid will move from inside the unit to the container. Continue until the fluid flow stops.

Replacement Parts List

Description	Part Number
TSS Cleaning Solution	81020
3½" Gauge Lens	81041
3½" Pressure Gage	81048
5/16" Adapter Hose	81051
3/8" Adapter Hose	81052
3½" Vacuum Pressure Gauge	81057
Air Solenoid	81058
Hose Strainer with Sight Glass	81061
Pressure/Vacuum Valve	81063
Air Regulator	81064
Wheel Assembly (1)	81066
Quick Connect Fitting	81067

Flow Diagram

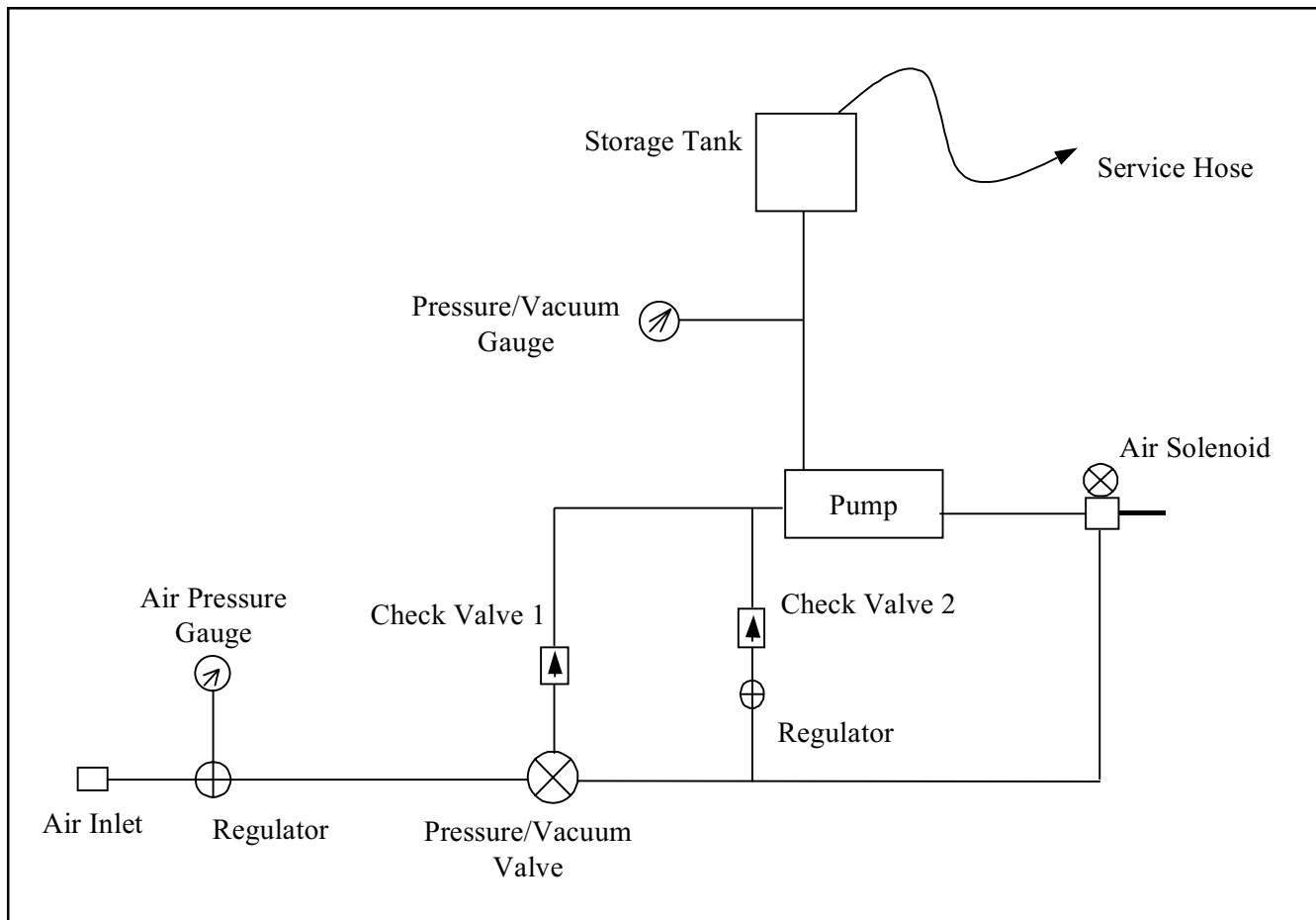

This product is warranted to be free from defects in workmanship, materials, and components for a period of one year from date of purchase. All parts required to repair defective products covered under the warranty will be at no charge. The following restrictions apply:

1. The limited warranty applies to the original purchaser only.
2. The warranty applies to the product in normal usage situations only, as described in the Operating Manual. The product must be serviced and maintained as specified.
3. This unit is field serviceable by the customer. Call the toll-free Technical Support Line, (800) 822-5561, for parts and technical assistance. **Do not** ship units to the factory.
4. Warranty claims are subject to factory inspection for product defect(s). The factory is the sole determinate of warranty coverage.
5. The manufacturer shall not be responsible for any additional costs associated with a product failure including, but not limited to, loss of work time, loss of fluids and unauthorized shipping and/or labor charges.
6. All warranty claims must be made within the specified warranty period. Proof-of-purchase date must be supplied to the manufacturer.
7. Use of this equipment with unauthorized solutions will void the warranty. Authorized solutions are listed in the operating manual or are available through our Technical Support Department.
8. If the product fails, it may be replaced at the option of the manufacturer.

This Limited Warranty does not apply if:

- The unit, or unit part, is broken by accident.
- The unit is misused, tampered with, or modified.
- The unit is used for any other purpose than as specified in this manual



Call toll-free **Technical Support Line**

800-822-5561

in the continental U.S. or Canada.

In all other locations, contact your local distributor. To help us serve you better, please be prepared to provide the model number, serial number, and date of purchase.

To validate your warranty, you must complete the warranty card attached to your unit and return it within ten days from date of purchase.

Due to ongoing product improvements,
we reserve the right to change design,
specifications and materials without notice.

SPX **ROBINAIR**

*SPX Corporation • 655 Eisenhower Dr. • Owatonna MN 55060
Customer Serv. 1-800-533-6127 • Tech. Serv. 1-800-822-5561*