

ROBINAIR

Operating Manual

AF-PRO PLUS

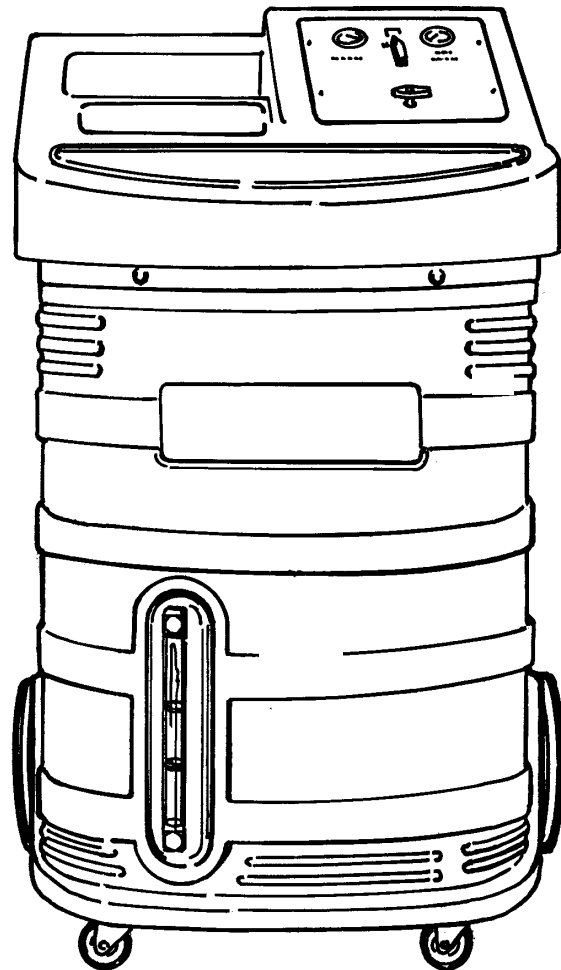

Model 75650

AF Pro Plus Coolant Recycler

Model 75650 AF Pro Plus Coolant Recycler

READ ALL INSTRUCTIONS COMPLETELY!

WARNING

Make certain all safety devices are functioning properly before operating this equipment. Before operating, read and understand the instructions and warnings in this manual. During operation, follow the procedures described in this manual.

Do not drink antifreeze or solution. If swallowed, give two glasses of water and induce vomiting. Call a physician. Ethylene glycol base. Avoid inhaling mist or hot vapors. If inhaled, remove to fresh air. Ethylene glycol causes birth defects in laboratory animals. Do not store in open or unlabeled containers. Wash thoroughly after handling. Solution may taste pleasant to animals, but is poisonous to them.

Contact with antifreeze/coolant may cause injury. Wear proper protective equipment including safety goggles when operating this equipment. If contact with eyes occurs, flush with cold water for 30 minutes and call physician immediately. If contact with skin occurs, thoroughly wash area with soap and water.

Do not use excessive RPM levels (high idle). The engine should run at low idle. Excessive RPM (high idle) may result in equipment malfunction and personal injuries.

Hot antifreeze/coolant can burn skin and injure eyes. Wear proper protective equipment including safety goggles, and follow all procedures as set forth in this manual.

Vehicle cooling systems which are hot are under pressure — opening a hot system except as described in this manual can cause an uncontrolled release of engine coolant. Do not open the radiator cap, and do not remove hoses from a hot system except as directed in this manual.

Never run a vehicle engine without adequate ventilation. Breathing vehicle emissions can cause sickness, injury, or death.

HANDLE BATTERY CONNECTION CABLES WITH EXTREME CAUTION — BATTERIES GENERATE EXPLOSIVE GASES DURING NORMAL BATTERY OPERATION. Working in the vicinity of a lead-acid or other automotive battery is dangerous. Wear complete eye protection. NEVER smoke or allow a spark or flame in the vicinity of a battery.

Do not pressurize the vehicle cooling system above its pressure rating. Doing so may result in cooling system failure and the release of engine coolant.

CAUTION! EQUIPMENT SHOULD BE OPERATED BY QUALIFIED PERSONNEL. Operator must be familiar with vehicle cooling systems, coolants, and the dangers they present.

This equipment is not designed for any other purposes than testing cooling systems and exchanging used antifreeze/coolant with new or recycled product.

Operator is responsible for complying with any and all applicable laws and regulations governing the use of this type of equipment as well as disposal of used antifreeze/coolant and used equipment and components.

SAVE THESE INSTRUCTIONS!

Glossary of Terms	3
Introduction	4
Operating Tips	4
<i>Figure 1—Front View of Unit</i>	4
<i>Figure 2—Rear View of Unit</i>	4
Set Up Instructions	5
<i>Figure 3—Items Shipped With Unit</i>	5
<i>Figure 4—Rear View of Unit</i>	6
<i>Figure 5—Front View of Unit</i>	7
Drain and Fill Procedures/Conventional Method	8
<i>Figure 6—Connections to Vehicle</i>	8
<i>Figure 7—Graduations on New Coolant Tank</i>	9
<i>Figure 8—Control Panel</i>	10
Drain and Fill Procedures/Heater Hose Access Process	13
<i>Figure 9—Tee Installation</i>	13
<i>Figure 10—Hookup to Unit</i>	14
On-Vehicle Reinhibiting	15
<i>Figure 11—Connections to Vehicle</i>	15
Refilling Using Vacuum Assist	19
Checking For Leaks	20
Optional Power Fill..	21
Emptying Procedure	22
<i>Figure 10—Rear View of Unit</i>	22
Flow Diagram	23
Replacement Parts List	23
Maintenance Instructions	24
Cleaning the Unit	24
Cleaning the Strainer	24
Limited Warranty	25

Table Of Contents

Antifreeze	Virgin product that has not been mixed with water
Coolant	A mixture of antifreeze and water
Unit	The 75650 AF Pro Plus Coolant Exchanger
System	The cooling system of the vehicle being serviced

Glossary

Introduction

The 75650 AF Pro Plus Coolant Recycler gives you everything you need to quickly remove, filter, and reinhibit coolant in a vehicle. Functions include drain and fill, pressure testing for leaks, and vacuum fill for use on an empty or partially empty system. The polyethylene portable cart provides durability and isn't damaged by coolant or other chemicals. The unit also has a tank within a tank feature, which keeps all serviced coolant at hand and doesn't require the use of additional storage vessels.

The 75650 saves time and labor. It reduces the time needed for a typical drain and fill procedure by at least 50%. It also eliminates the need to wait for a hot system to cool down. This process also substantially reduces damaging air bubbles and air locks in a system.

The unit provides a means for fast, easy filtering of a cooling system clogged by accumulations of rust and other contaminants.

In addition, the pressure function can check the system for leaks after servicing the system.

OPERATING TIPS

1. Before filling a vehicle with new/recycled coolant, be sure there is an adequate amount of coolant in the unit's New Coolant tank. The amount of coolant in the tank can be seen by looking at the sight glass on the front of the unit. An alarm will sound during operation if the New Coolant tank is empty.

2. A 12-volt diaphragm pump circulates coolant during the drain and fill procedure. A 12V DC electric source is required. It is intended that the power leads be connected to the vehicle being serviced; proper operation will not drain the vehicle battery. To power the vacuum, you need a source of compressed air regulated at 75 psi (517 kPa, 5.2 bar) to 120 psi (827 kPa, 8.3 bar) with a 5 cfm (116 l/min.) capacity.

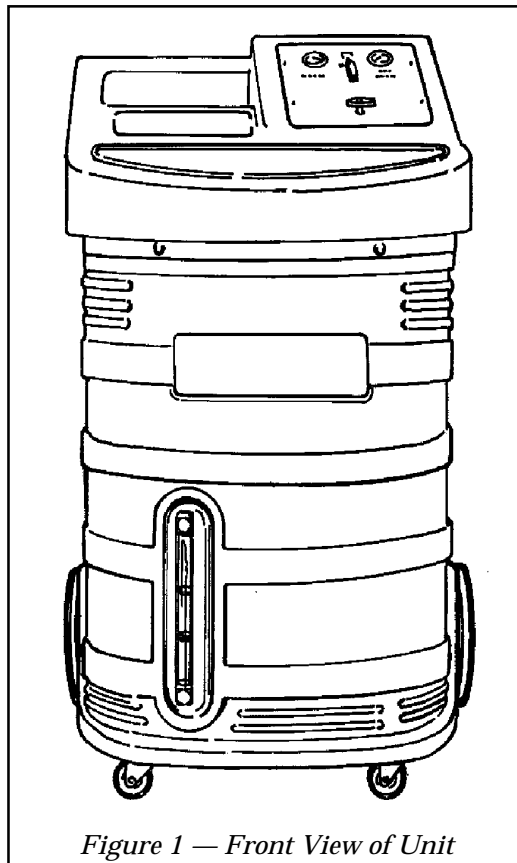

Figure 1 — Front View of Unit

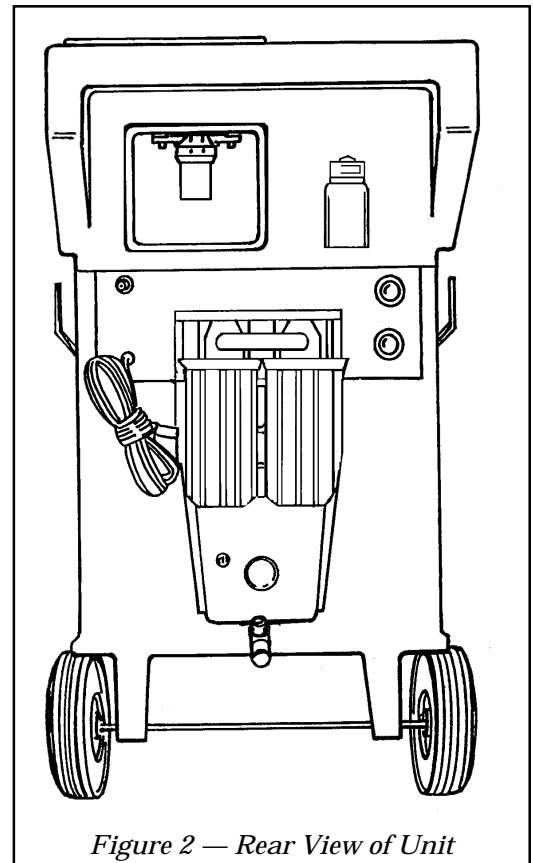

Figure 2 — Rear View of Unit

The AF Pro Plus Coolant Recycler comes complete and ready to use.

1. Unpack all materials listed below (and shown in Figure 3). Check to see that you have the following items:

- | | |
|--|---|
| A (1) Large Radiator Cap Adapter | J (2) Quick Connect Couplers |
| B (1) Small Radiator Cap Adapter | K (2) Step Adapters |
| C (1) $\frac{5}{16}$ " Siphon Hose Assembly | L (1) Coolant Hose Assembly (Inlet)* |
| D (1) $\frac{3}{8}$ " Siphon Hose Assembly | M (1) Coolant Hose with View Window Assembly (Outlet)* |
| E (1) $1\frac{1}{4}$ " Hose Adapter | N (2) Garden Hose Gaskets* |
| F (1) $1\frac{3}{8}$ " Hose Adapter | |
| G (1) $1\frac{1}{2}$ " Hose Adapter | <i>*Not Shown</i> |
| H (2) Quick Connect Nipples (male thread) | |
| I (1) Quick Connect Nipple (female thread) | |

Part numbers are also listed in the Replacement Parts List on page 23.

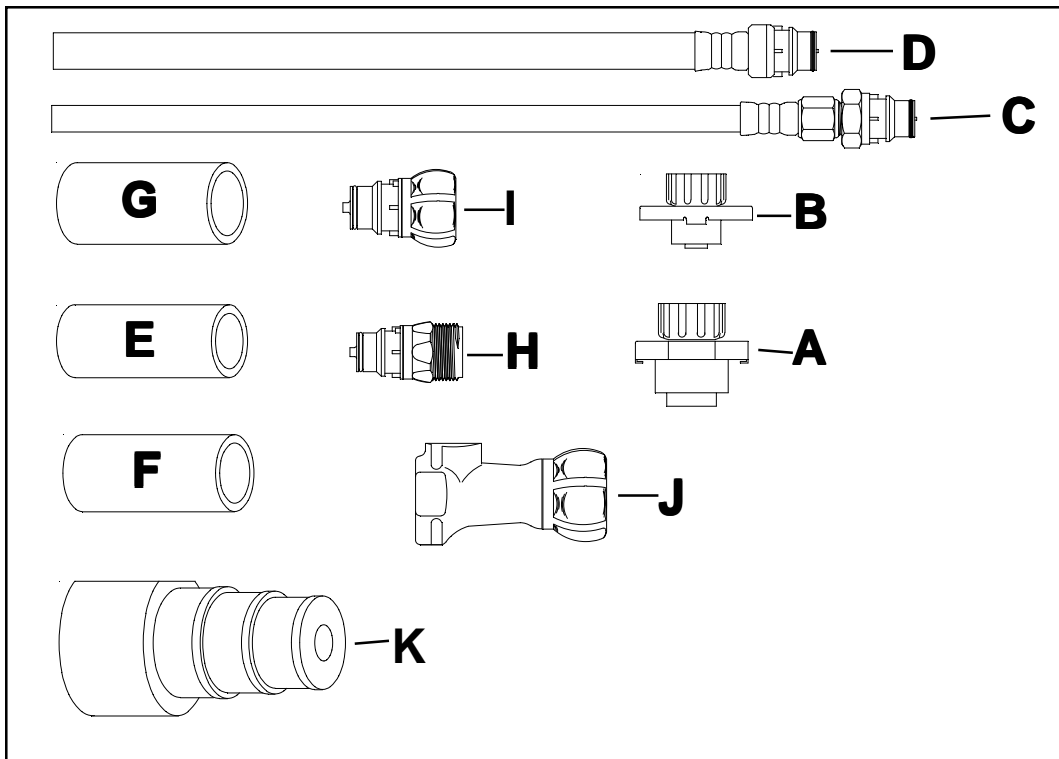

Figure 3 — Items Shipped With Unit

Set Up Instructions

2. Connect a 1/4" male fitting to the air supply inlet located on the upper left side of the unit's rear panel (see Figure 5). You will have to furnish this fitting.
3. Add at least three gallons (11.4 liters) of coolant by pouring the coolant into the large sink located on the top front of the unit. Use a 50/50 mix of new antifreeze and water **or** recycled coolant which has been adjusted to a 50/50 mix.

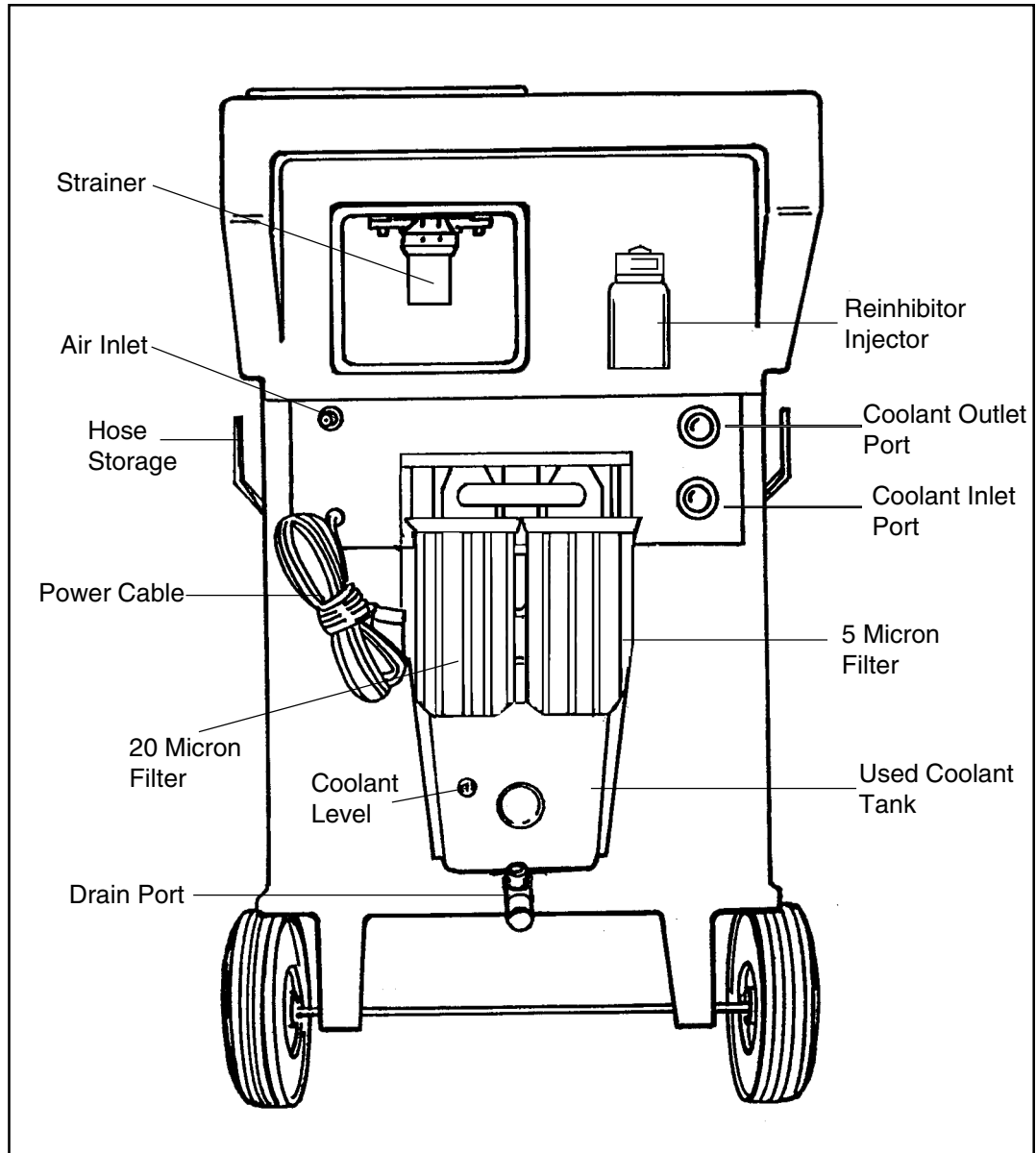

Figure 4 — Rear View of Unit

4. Connect the solid black hose to the Coolant Inlet port. Connect the hose with the clear window to the Coolant Outlet port.
5. Attach a quick connect coupler to the end of each hose. Insert a rubber hose gasket into each step adapter.

Set Up Instructions

6. Make sure that the filter housings are tightened securely. Keep extra filters on hand because they must be replaced.
7. Change the filters whenever the pressure drops below normal operating psi. Either filter could become clogged quickly, however, you can expect the 20 micron filter to become clogged first.
8. Observe the clarity of the coolant through the Coolant Outlet hose view window. If the coolant does not run clear after the entire filtration process, the filters need to be replaced.
9. To change filters, turn the main power switch to OFF. Unscrew the filter housing(s), remove the dirty filter(s), and replace with a new filter(s). Reinstall the filter housing(s) and tighten securely.

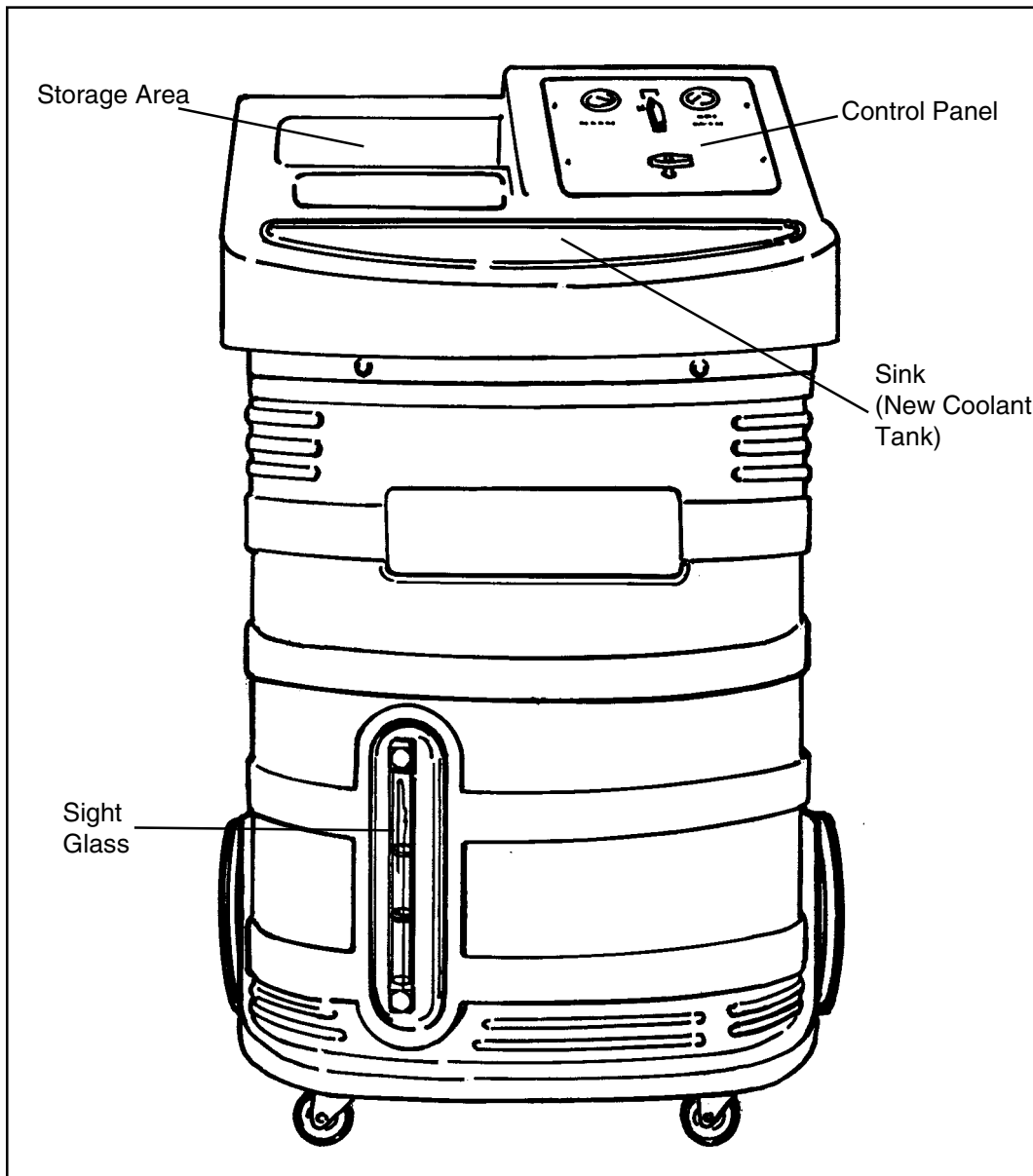

Figure 5 — Front View of Unit

Drain & Fill Procedures/ Conventional Method

⚠ WARNING! ⚠

Contact with antifreeze/coolant can cause injury. Wear proper protective equipment and read the warnings at the beginning of this manual. Follow instructions carefully. Failure to perform the procedures as described can result in personal injury and damage to the vehicle and equipment.

IMPORTANT! To protect the pump and prevent air from entering the system, an alarm will sound if there is not enough coolant in the unit.

CAUTION! Before performing a drain and fill procedure, be sure to purge the vehicle's cooling system of any flush product. Follow the flush manufacturer's directions.

The AF Pro Plus Coolant Recycler allows you to quickly filter and inhibit the coolant in the vehicle. This process substantially reduces air bubbles and prevents air locks in the system. The entire process should take 15 to 20 minutes.

This procedure can be performed on an engine that is cool or hot. The process can be completed faster if the engine is at operating temperature.

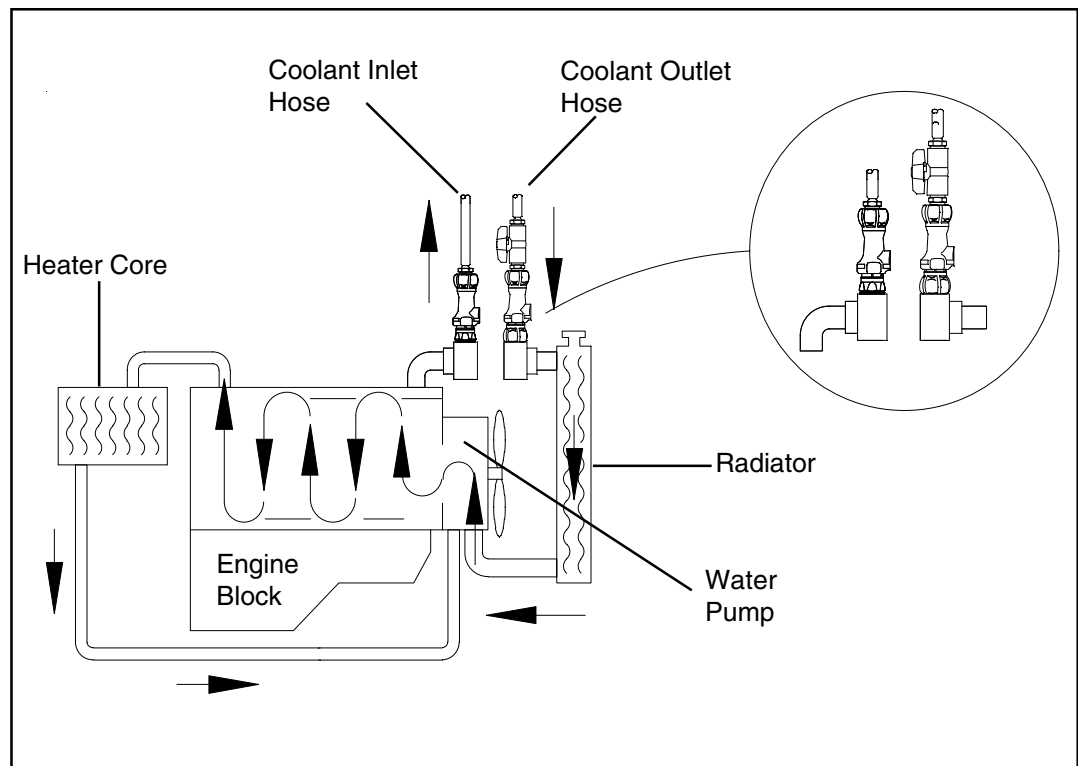

Figure 6 — Connections to Vehicle

1. Position the AF Pro Plus near the vehicle's engine compartment.

CAUTION! Be sure the Used Coolant tank has enough room to hold the vehicle's capacity.

2. In order to fill the New Coolant tank with the proper amount of new or recycled coolant, check the sight glass on the front of the unit for the graduation levels. These levels depict the amount of coolant in the tank. Remember to check the manufacturer's specifications for engine coolant capacity. Use a 50/50 mix of new antifreeze and water **or** recycled coolant which has been adjusted to a 50/50 mix.

Once you have filled the New Coolant tank, set the top ring on the sight glass in line with the level of coolant in the tank. Place the second ring at the level of coolant needed to meet the vehicle's requirements. This serves as a guide when measuring coolant in the tank.

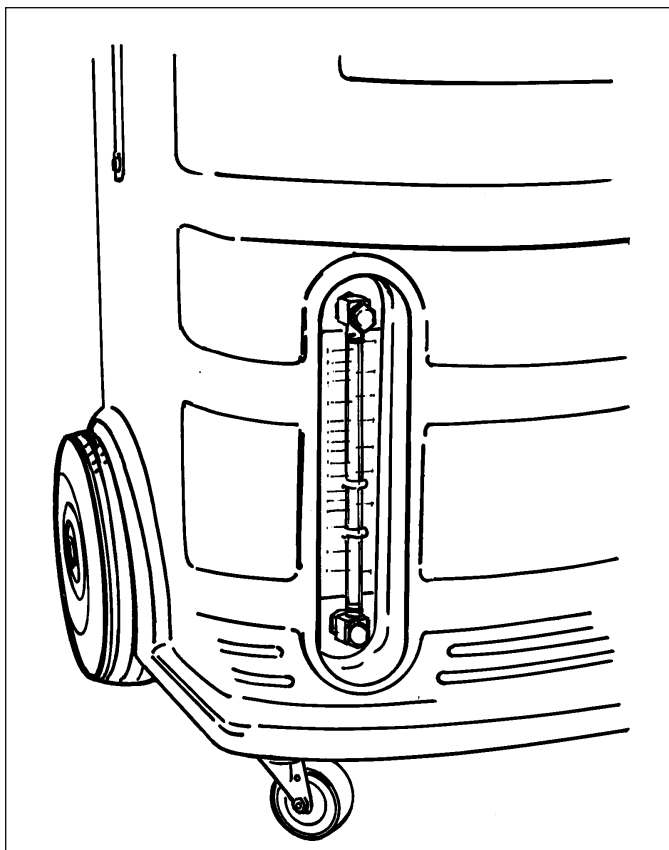

Figure 7 —
Graduations on
New Coolant Tank

⚠ WARNING! ⚠

Handle battery connection cables with extreme caution — batteries generate explosive gases during normal battery operation. Working in the vicinity of a lead-acid or other automotive battery is dangerous. Wear complete eye protection. **NEVER** smoke or allow a spark or flame in the vicinity of a battery.

3. Connect the red power lead to the “+” (positive) post of the vehicle battery or to another 12V power source. Then connect the black power lead to an engine ground, **not** the battery “-” terminal.

Verify that the Power Switch is in the OFF position.

4. **If the system is hot and pressurized**, relieve the pressure in the system as follows:
 - Remove the vehicle's overflow tank hose from the fitting on the radiator neck.

Drain & Fill Procedures/ Conventional Method

Drain & Fill Procedures/ Conventional Method

- Attach the correct size vacuum siphon hose to the overflow fitting on the vehicle, then connect the Quick Coupler of the Coolant Inlet hose (solid black) to the siphon hose.
 - Turn the upper control panel valve to DRAIN AND FILL. Turn the lower control panel valve to NEW COOLANT.
 - Connect the air supply hose to the air supply inlet fitting on the back left of the unit. Make sure incoming pressure is regulated between 75 psi (517 kPa, 5.2 bar) and 120 psi (827 kPa, 8.3 bar) at 5 cfm (116 l/m).
 - When the vacuum gauge on the control panel shows 20 in. Hg of vacuum, **slowly** remove the vehicle's radiator cap.
 - Disconnect the siphon hose from the vehicle's radiator neck.
- If the system is cold:**
- **Slowly** remove the vehicle's radiator cap.
 - Turn the upper control panel valve to
- DRAIN AND FILL. Turn the lower control panel valve to NEW COOLANT.
- Connect the air supply hose to the air supply inlet fitting on the back left of the unit. Make sure incoming pressure is regulated between 75 psi (517 kPa, 5.2 bar) and 120 psi (827 kPa, 8.3 bar) at 5 cfm (116 l/m).
5. Remove the cap on the vehicle's overflow tank. Then attach a vacuum siphon hose to the Coolant Inlet hose (solid black). To remove any remaining coolant, place the vacuum siphon hose in the over-flow tank.
 6. Place the vacuum siphon hose attached to the Coolant Inlet hose (solid black) in the radiator. Remove enough coolant to lower the coolant level in the radiator below the level of the upper radiator inlet hose fitting.
 7. Disconnect the air supply.
 8. Replace the caps on the vehicle's radiator and overflow tank and reconnect the overflow hose.

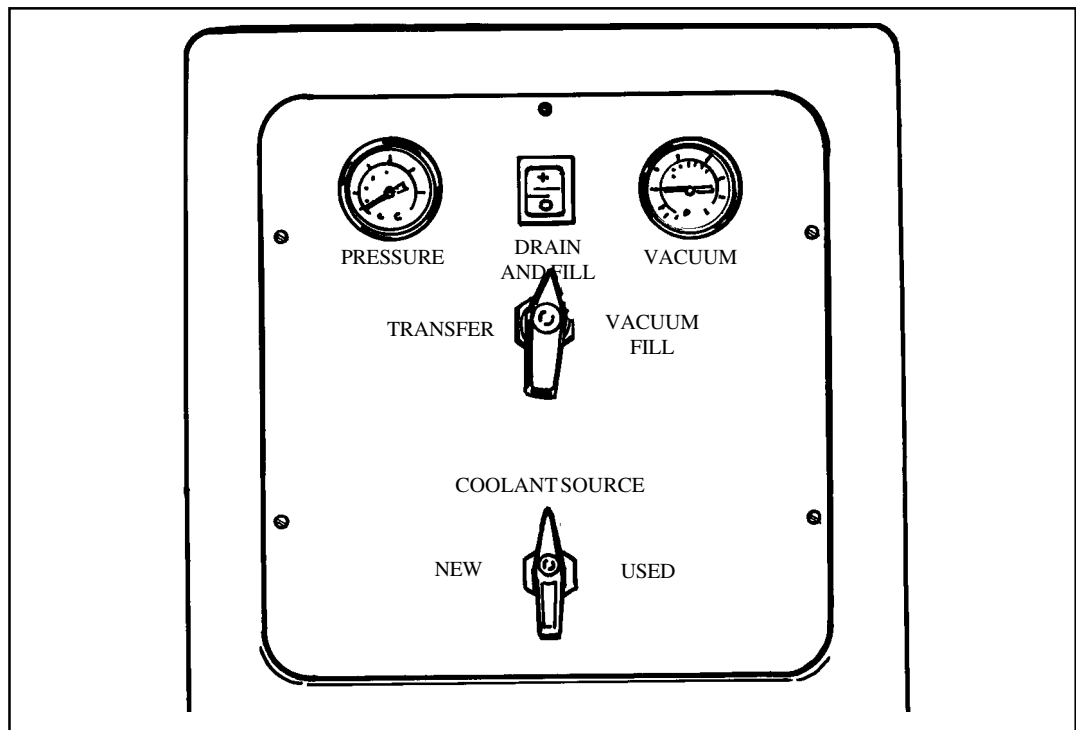

Figure 8 — Control Panel

9. Disconnect the vacuum siphon hose from the Coolant Inlet hose (solid black). Store the siphon hose and its fitting on the side brackets.
10. Examine the vehicle's upper radiator hose to determine which location (at either the radiator or engine) will be most convenient to remove one end of the radiator hose and to install the hose adapter.
11. Remove the hose clamp securing the radiator hose to the radiator or the engine, and remove the hose from the radiator or engine. Be careful not to overstress the radiator hose fitting.
12. Connect the male quick connect nipples to both step adapters.
13. Insert a step adapter onto the engine side hose and another onto the radiator side hose.
14. Secure the step adapters to the radiator hose and adapter hose with hose clamps. **You will have to supply these clamps.**
15. Connect the Coolant Outlet hose (with clear window) to the radiator side connection and open the valve on Coolant Outlet hose.
16. Connect the Coolant Inlet hose (solid black) to the engine side connection.
17. Turn the upper control panel valve to DRAIN AND FILL and turn the lower control panel valve to NEW COOLANT. Turn the main power switch ON.

⚠ WARNING! ⚠

Before starting the vehicle, be sure it is in Park or Neutral with the emergency brake on.

Do not use excessive RPM levels (high idle). The engine should run at low idle. Excessive RPM (high idle) may result in equipment malfunction and personnel injuries.

Never run a vehicle without adequate ventilation. Breathing vehicle emissions can cause sickness, injury or death.

Keep hands and service components/tools away from moving parts on the vehicle.

18. Start the vehicle. Coolant will be pumped from the New Coolant tank into the vehicle. Used coolant will be transferred to the Used Coolant tank.

Note: Coolant exchange will not occur unless the thermostat is open. If the thermostat will not open, turn the vehicle off, and check the cooling system components. If the flow stops, monitor the engine temperature. Continue to run the vehicle — the thermostat should open and the flow will start.

IMPORTANT! If the alarm sounds during the drain and fill process, immediately turn off the vehicle's engine to avoid discharging excess coolant from the cooling system. Set the control panel switch to OFF.

Drain & Fill Procedures/ Conventional Method

Drain & Fill Procedures/ Conventional Method

19. When the correct amount of coolant has been exchanged in the vehicle, close the valve on the Coolant Outlet hose (with clear window). Wait 10 to 15 seconds, then turn off the engine and set the control panel switch to OFF.

⚠ WARNING! ⚠

The radiator may contain hot coolant. Wear eye and hand protection.

20. Disconnect the Coolant Outlet hose (with clear window) from the step adapter. Then, disconnect the Coolant Inlet hose from the other step adapter.
21. Remove the hose connectors and clamps from the radiator hose and the rubber adapter hose. Disconnect from the radiator side first, then disconnect from the engine side.
22. Reconnect the radiator hose to the fitting (radiator or engine) on the vehicle from which it was removed. Secure with a clamp.
23. Remove the vehicle's radiator cap. With the siphon hose attached to the Coolant Outlet hose (with clear window), turn the control panel switch to ON, fill the vehicle's overflow tank and top off the radiator to the correct level. Use the valve on the Coolant Outlet hose (with clear window) to control the flow.
24. Close the valve on the Coolant Outlet hose (with clear window), then disconnect the siphon hose from the Coolant Outlet hose.
25. Set the control panel switch to OFF. Replace the radiator and overflow caps.
26. Disconnect the black power lead, then disconnect the red power lead from the vehicle battery or 12V power source. Store the hoses and power leads on the side brackets. If the Used Coolant tank is full, you may drain it by following the steps on page 18 of this manual.

The drain and fill procedure is now complete. Start the vehicle and check for leaks (see *Checking for Leaks* on page 16).

Installing The Tee

Use this process to reverse the flow of coolant in order to loosen and remove scale, rust, and other contaminants from the cooling system.

1. On the vehicle, locate the heater outlet hose that runs between the heater core (in the fire wall) and the water pump or radiator. The tee will be installed in the heater outlet hose (see Figure 9).

CAUTION! Be sure that you locate the heater outlet hose and not the heater inlet hose that runs between the heater core and the engine block or thermostat housing.

2. Find a convenient spot on the heater outlet hose to install the tee. Clamp pinch-off pliers on the hose two or four inches on each side of the installation point.

3. Using a hose cutter, cut completely through the heater outlet hose at the selected point.
4. Slide a hose clamp (not supplied) onto each cut section of the heater hose to pinch-off pliers. Select the correct size tee (not supplied) to fit on the hose sections. Connect the tee to the hose sections. Slide each clamp onto the connection and tighten the hose clamps.

NOTE: If the tee is not already capped, install a tee cap on the tee. Make sure the cap contains a rubber washer.

5. Remove the pinch-off pliers.

NOTE: This tee will permanently remain in place on the vehicle.

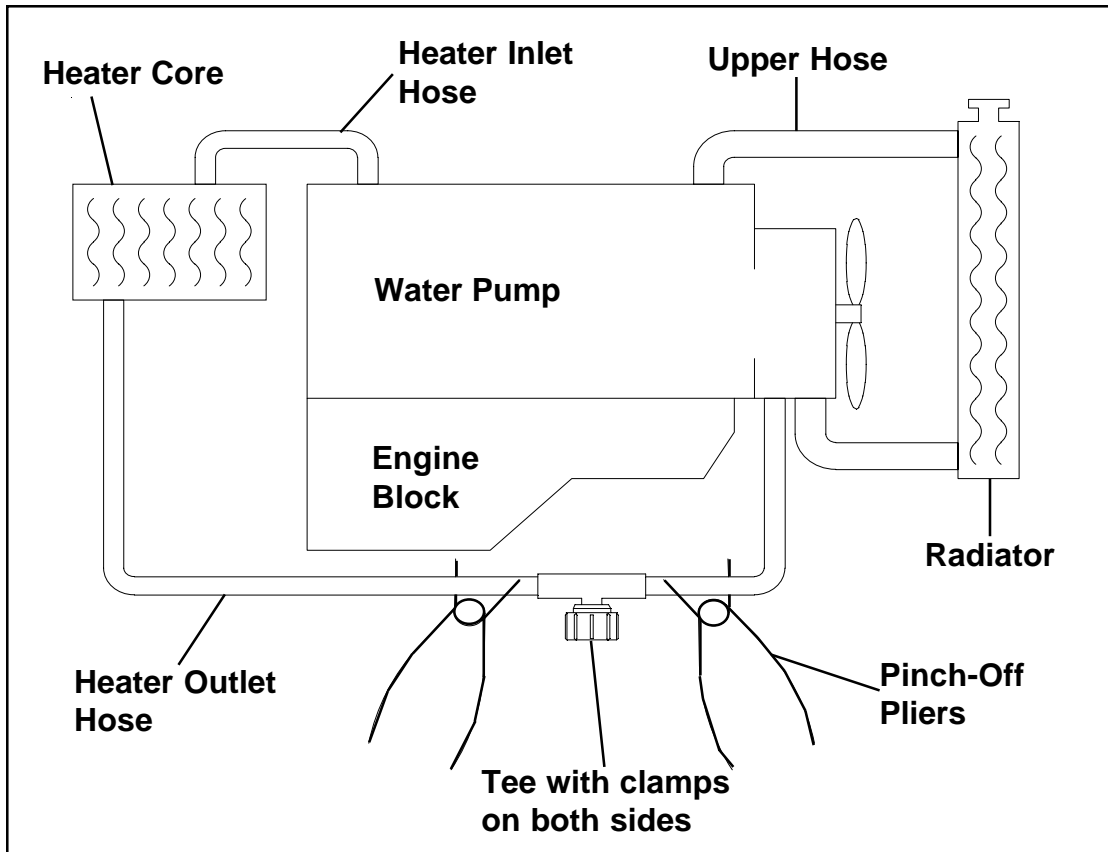

Figure 9 - Tee Installation

Drain & Fill Procedures/ Heater Hose Access Process

Drain & Fill Procedures/ Heater Hose Access Process

1. Follow steps 1 - 14 from the *Drain & Fill Procedures/Conventional Method* section (pages 8-11).
2. Using pinch-off pliers, pinch off the heater hose on both sides of the tee. Remove the tee cap and connect the quick connect nipple (female) to the tee. Remove the pinch-off pliers between the tee and the heater core (see Figure 10).
3. Connect the Coolant Outlet hose (with view window) to the quick connect nipple and open the valve on the Coolant Outlet hose. Connect the Coolant Inlet hose (solid black) to the radiator side connector.
*Coolant will be pumped from the New Coolant tank into the vehicle. Used coolant will be transferred to the Used Coolant tank.

WARNING! DO NOT START THE VEHICLE! This procedure does not require the vehicle to run during Drain & Fill or recycling procedure. Failure to perform procedures as described can result in personal injury and damage to the vehicle and equipment.

4. When the correct amount of coolant has been exchanged in the vehicle, close the valve on the Coolant Outlet hose (with view window) and set the control panel switch to OFF.
5. Disconnect the Coolant Outlet hose (with view window) from the quick connect nipple. Disconnect the Coolant Inlet hose (solid black) from the step adapter.
6. Remove the hose connectors and clamps from the radiator hose and the rubber adapter hose. Disconnect from the radiator side first, then disconnect from the engine side.
7. Reconnect the radiator hose to the fitting (radiator or engine) on the vehicle from which it was removed. Secure with a clamp.
8. Remove the vehicle's radiator cap. With the siphon hose attached to the Coolant Outlet hose (w/clear window), turn the control panel switch to ON, fill the vehicle's overflow tank and top off the radiator to the correct level. Use the valve on the Coolant Outlet hose (w/clear window) to control the flow.
9. Close the valve on the Coolant Outlet hose (w/clear window), then disconnect the siphon hose from the Coolant Outlet hose.
10. Set the control panel switch to OFF. Replace the radiator and overflow caps.
11. After disconnecting the quick connect nipple, install a cap with a rubber washer onto the tee.
12. Disconnect the black power lead, then disconnect the red power lead from the vehicle battery or 12V power source. Store the hoses and power leads on the side brackets. If the Used Coolant tank is full, you may drain it (see page 18).

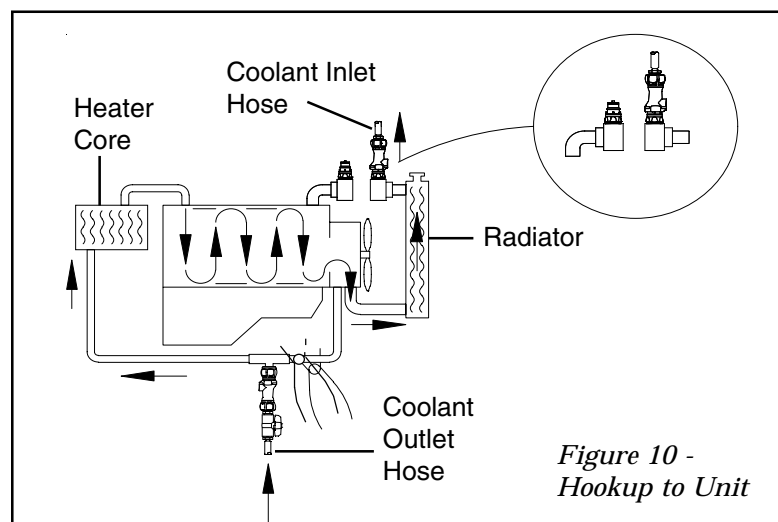

Figure 10 -
Hookup to Unit

⚠ WARNING! ⚠

Contact with antifreeze/coolant can cause injury. Wear proper protective equipment and read the warnings at the beginning of this manual.

Follow instructions carefully. Failure to perform the procedures as described can result in personal injury and damage to the vehicle and equipment.

CAUTION! During filtering, unit components are extremely hot! Wear adequate eye and hand protection.

The AF Pro Plus Coolant Recycler allows you to quickly filter and reinhibit the coolant in the vehicle. The entire process should take 15 to 20 minutes.

This procedure can be performed on an engine that is cool or hot. The process can be completed faster if the engine is at operating temperature.

1. Position the AF Pro Plus near the vehicle's engine compartment.

CAUTION! Be sure the Used Coolant tank has enough room to hold the vehicle's capacity.

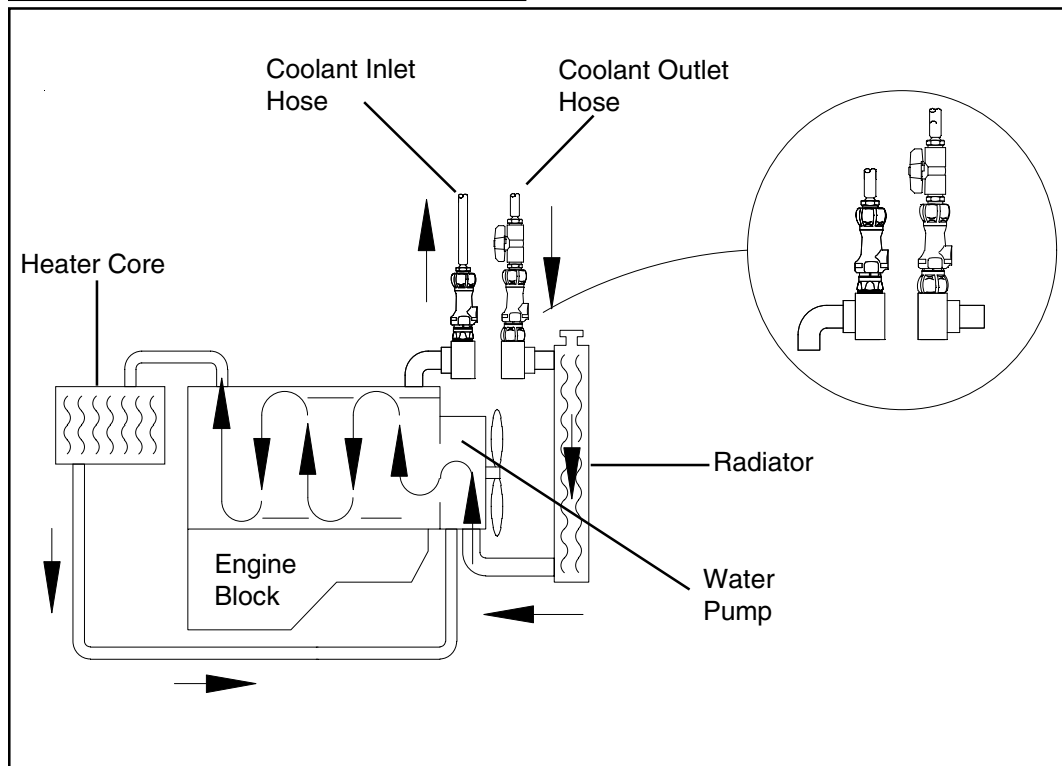

Figure 11 — Connections to Vehicle

⚠ WARNING! ⚠

Handle battery connection cables with extreme caution — batteries generate explosive gases during normal battery operation. Working in the vicinity of a lead-acid or other automotive battery is dangerous. Wear complete eye protection. NEVER smoke or allow a spark or flame in the vicinity of a battery.

2. Connect the red power lead to the “+” (positive) post of the vehicle battery or to another 12V power source. Then connect the black power lead to an engine ground, *not* the battery “-” terminal.

Verify that the Power Switch is in the OFF position.

3. ***If the system is hot and pressurized,*** relieve the pressure in the system as follows:
 - Remove the vehicle's overflow tank hose from the fitting on the radiator neck.

On-Vehicle Reinhibiting

CAUTION! Be sure used coolant appears on the Coolant Level on the Used Coolant tank. There **MUST** be coolant present before starting this process. See page 6 for the location of the Coolant Level.

On-Vehicle Reinhibiting

- Attach the correct size vacuum siphon hose to the overflow fitting on the vehicle, then connect the Quick Coupler of the Coolant Inlet hose (solid black) to the siphon hose.
 - Turn the upper control panel valve to DRAIN AND FILL. Turn the lower control panel valve to NEW COOLANT.
 - Connect the air supply hose to the air supply inlet fitting on the back left of the unit. Make sure incoming pressure is regulated between 75 psi (517 kPa, 5.2 bar) and 120 psi (827 kPa, 8.3 bar) at 5 cfm (116 l/m).
 - When the vacuum gauge on the control panel shows 20 in. Hg of vacuum, **slowly** remove the vehicle's radiator cap.
 - Disconnect the siphon hose from the vehicle's radiator neck.
- If the system is cold:**
- **Slowly** remove the vehicle's radiator cap.
 - Turn the upper control panel valve to DRAIN AND FILL. Turn the lower control panel valve to NEW COOLANT.
4. Remove the cap on the vehicle's overflow tank. Check the freeze point of the coolant using the test strips provided (follow directions on the strip) or with any other acceptable method. The correct freeze point level at a 50/50 mix is -34F (-36.7C).
 5. Attach a vacuum siphon hose to the Coolant Inlet hose (solid black). To remove any remaining coolant, place the vacuum siphon hose in the overflow tank.
 6. Place the vacuum siphon hose attached to the Coolant Inlet hose (solid black) in the radiator. Remove enough coolant to lower the coolant level in the radiator below the level of the upper radiator inlet hose fitting.
 7. Disconnect the air supply.
 8. Replace the caps on the vehicle's radiator and overflow tank. Reconnect the overflow hose.

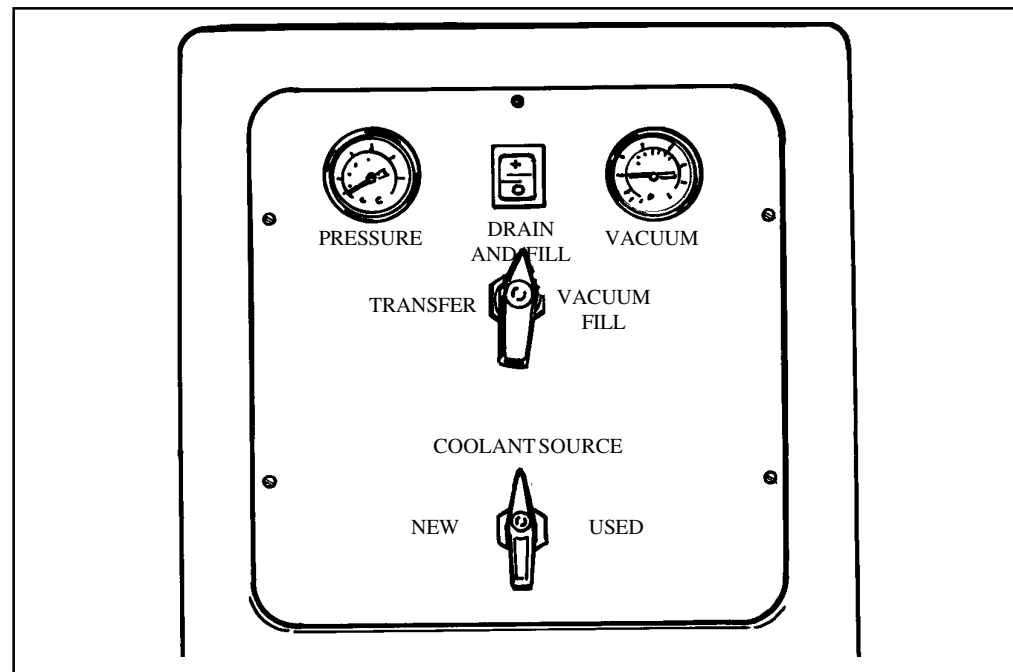

Figure 11 — Control Panel

9. Disconnect the vacuum siphon hose from the Coolant Inlet hose (solid black). Store the siphon hose and its fitting in the storage area.
10. Examine the vehicle's upper radiator hose to determine which location (at either the radiator or engine) will be most convenient to remove one end of the radiator hose and to install the hose adapter.
11. Remove the hose clamp securing the radiator hose to the radiator or the engine, and remove the hose from the radiator or engine. Be careful not to overstress the radiator hose fitting.
12. Connect the male quick connect nipples to both step adapters.
13. Insert a step adapter onto the engine side hose and another onto the radiator side hose.
14. Secure the step adapters to the radiator hose and adapter hose with hose clamps. **You will have to supply these clamps.**
15. Connect the Coolant Outlet hose (with clear window) to the radiator side connection and open the valve on Coolant Outlet hose.
16. Connect the Coolant Inlet hose (solid black) to the engine side connection.
17. Unscrew the Reinhibrator Injector bottle on the back of the unit. Add reinhibitor (not included, see the *Replacement Parts List*) to the bottle based on the vehicle's coolant capacity:
 - 6-15 quarts (6-14 liters) - add one bottle, 12 fl. oz. (355ml)
 - 16-30 quarts (15-28 liters) - add two bottles, 24 fl. oz. (710ml)

You may have to repeat this process several times during this procedure to meet the vehicle's capacity.
18. Turn the control panel valve to DRAIN AND FILL. Turn the lower control panel valve to USED COOLANT.

19. Turn the main power ON.



Before starting the vehicle, be sure it is in Park or Neutral with the emergency brake on.

Do not use excessive RPM levels (high idle). The engine should run at low idle. Excessive RPM (high idle) may result in equipment malfunction and personnel injuries.

Never run a vehicle without adequate ventilation. Breathing vehicle emissions can cause sickness, injury or death.

Keep hands and service components/tools away from moving parts on the vehicle.

20. Start the vehicle. Coolant from the engine will be circulated into the Used Coolant tank, then pumped through the unit's filters and the coolant will be returned to the engine.

Note: Coolant exchange will not occur unless the thermostat is open. If the thermostat will not open, turn the vehicle off, and check the cooling system components. If the flow stops, monitor the engine temperature. Continue to run the vehicle — the thermostat should open and the flow will start.

IMPORTANT! Coolant exchange will not occur unless the thermostat is open. If the thermostat will not open, stop the engine and check the cooling system components. If the flow stops, monitor the engine temperature. Continue to run the engine - the thermostat should and the flow will start.

21. Open the valve on the Reinhibrator Injector. Allow reinhibitor to be drawn into the unit. When the bottle is almost empty, turn the valve off. Unscrew the bottle and refill it with additional reinhibitor (if required). Screw the bottle back onto the unit and repeat this process as required.

On-Vehicle Reinhibiting

CAUTION! Do not allow air to be drawn into the unit. Damage to equipment and/or vehicle may occur.

On-Vehicle Reinhibiting

22. Allow the coolant to circulate between the vehicle and the unit at least two cycles. Wait 10 to 15 seconds, then turn off the engine and set the control panel switch to OFF.

⚠ WARNING! ⚠

**The radiator may contain hot coolant.
Wear eye and hand protection.**

23. Disconnect the Coolant Outlet hose (with clear window) from the step adapter. Then, disconnect the Coolant Inlet hose from the other step adapter.
24. Remove the hose connectors and clamps from the radiator hose and the rubber adapter hose. Disconnect from the radiator side first, then disconnect from the engine side.
25. Reconnect the radiator hose to the fitting (radiator or engine) on the vehicle from which it was removed. Secure with a clamp.
26. Remove the vehicle's radiator cap. With the siphon hose attached to the Coolant Outlet hose (with clear window), turn the control panel switch to ON, fill the vehicle's overflow tank and top off the radiator to the correct level. Use the valve on the Coolant Outlet hose (with clear window) to control the flow.
27. Close the valve on the Coolant Outlet hose (with clear window), then disconnect the siphon hose from the Coolant Outlet hose.
28. Set the control panel switch to OFF. Replace the radiator and overflow caps.
29. Disconnect the black power lead, then disconnect the red power lead from the vehicle battery or 12V power source. Store the hoses and power leads on the side brackets. If the Used Coolant tank is full, you may drain it by following the steps on page 18 of this manual.

The On-Vehicle Reinhibiting procedure is now complete. Start the vehicle and check for leaks (see *Checking for Leaks* on page 16).

CAUTION! Do not perform this procedure on a full system!

If you have to make repairs to the vehicle, the vacuum function lets you fill a partially or completely empty system instead of draining and filling at the same time.

Be sure the New Coolant tank has the amount of antifreeze/coolant needed for the vehicle being serviced by checking the sight glass on the front of the unit. Also, check the manufacturer's specifications for engine coolant capacity. Use a 50/50 mix of new antifreeze and water *or* recycled coolant which has been adjusted to a 50/50 mix.

⚠ WARNING! ⚠

The radiator may contain hot coolant. Wear eye and hand protection.

1. First, connect the red power lead to the "+" (positive) post of the vehicle battery or to another 12V power source. Then connect the black power lead to an engine ground, *not* the battery "-" terminal.

⚠ WARNING! ⚠

Handle battery connection cables with extreme caution — batteries generate explosive gases during normal battery operation. Working in the vicinity of a lead-acid or other automotive battery is dangerous. Wear complete eye protection. NEVER smoke or allow a spark or flame in the vicinity of a battery.

2. **Slowly** remove the vehicle's radiator cap (on vehicles with closed loop cooling systems, remove the overflow tank cap).
3. Connect and tighten the appropriate size radiator cap adapter to the radiator fill neck. Connect the Coolant Inlet hose (solid black) to the radiator service cap adapter.
4. Turn the upper control panel valve to DRAIN AND FILL and the lower control panel valve to NEW COOLANT.

5. Connect the air supply hose to the air supply inlet fitting. Be sure incoming pressure is regulated between 75 psi (517 kPa, 5.2 bar) and 120 psi (827 kPa, 8.3 bar) at 5 cfm (116 l/m). Allow the system to pull down to 20-28 in. Hg.
6. Disconnect the air supply. Turn the control panel valve to VAC FILL. When the vacuum gauge reaches zero, disconnect the Coolant Inlet hose (solid black) from the radiator cap adapter.
7. Remove the radiator cap adapter and the cap from the overflow tank.
8. Attach one of the unit's siphon hose assemblies to the Coolant Outlet hose (w/clear window). Turn the control panel valve to DRAIN AND FILL. Turn the valve on the Coolant Outlet hose to OFF, then set the control panel switch to ON. Using the valve on the Coolant Outlet hose to control the flow, fill the radiator and overflow tank to the correct level.
9. When the system has been filled, set the control panel switch to OFF and remove the siphon hose and store it. Replace the caps on the radiator and overflow tank.
10. Disconnect the black power lead, then disconnect the red power lead from the vehicle battery or 12V power source. Store the hoses and power leads on the side brackets.
11. If the Used Coolant tank is full, you can transfer the used coolant to a suitable storage container as described in the *Optional Power Fill* section on page 18.

Refilling Using Vacuum Assist

Checking For Leaks

You can check a cooling system for leaks using the built-in pressure testing function prior to servicing or after. If the system holds a pressure level, you know it is leak-free and you can refill it with coolant. However, if it doesn't hold a pressure level, you know there is a leak that must be repaired.

Be sure the New Coolant tank has the amount of antifreeze/coolant needed for the vehicle being serviced by checking the sight glass on the front of the unit. Also, check the manufacturer's specifications for engine coolant capacity. Use a 50/50 mix of new antifreeze and water **or** recycled coolant which has been adjusted to a 50/50/ mix.

WARNING!

Handle battery connection cables with extreme caution — batteries generate explosive gases during normal battery operation. Working in the vicinity of a lead-acid or other automotive battery is dangerous. Wear complete eye protection. NEVER smoke or allow a spark or flame in the vicinity of a battery.

1. First, connect the red power lead to the "+" (positive) post of the vehicle battery or to another 12V power source. Then connect the black power lead to an engine ground, *not* the battery "-" terminal.

WARNING!

The radiator may contain hot coolant. Wear eye and hand protection.

2. **Slowly** remove the vehicle's radiator cap, connect and tighten the appropriate radiator cap adapter, then connect the Coolant Outlet hose (with clear window) to the radiator cap adapter.
3. Turn the upper control panel valve to DRAIN AND FILL and the lower control panel valve to NEW COOLANT. Set the control panel switch to ON.

4. Open the valve on the Coolant Outlet hose (with clear window). The pump will pressurize the system to about 7 psi.
5. Watch the pressure gauge for any pressure loss. The system should hold a constant pressure; the pump will try to maintain the pressure at 7 psi (48 kPa, 0.5 bar). If there is a loss of pressure, check for system leaks. If a leak is noted, set the control panel switch to OFF. Then turn the valve on the Coolant Outlet hose (w/clear window) to OFF and repair the leak. If necessary, drain the coolant before making repairs.
6. Repeat Steps 3 and 4 until no loss of pressure and no leaks are indicated. If you drained the system before making repairs, refill using vacuum assist (refer to *Refilling Using Vacuum Assist* section on page 15). Repeat this entire procedure.
7. To end the pressure test, set the control panel switch to OFF. Close the valve on the Coolant Outlet hose (with clear window). Disconnect the Coolant Outlet hose from the radiator cap adapter.

WARNING!

The system is under pressure. Be sure to remove the radiator cap adapter very slowly in the next step.

8. To relieve pressure, connect the Coolant Inlet hose (solid black) to the radiator cap adapter. **Slowly** remove the radiator cap adapter. Replace the vehicle's radiator cap.
9. Disconnect the black power lead, then disconnect the red power lead from the vehicle battery or 12V power source. Store the hoses and power leads on the side brackets.

The unit has an optional powered fill and discharge feature, which provides a “hands-off” method of transferring used coolant to another approved bulk container.

USING THE POWER FILL

⚠ WARNING! ⚠

Handle battery connection cables with extreme caution — batteries generate explosive gases during normal battery operation. Working in the vicinity of a lead-acid or other automotive battery is dangerous. Wear complete eye protection. NEVER smoke or allow a spark or flame in the vicinity of a battery.

1. Connect the power leads to the vehicle battery or to another 12V power source. The red lead goes to the “+” (positive) post first, then the black lead to an engine ground, **not** the battery “-” terminal.
2. Connect a siphon hose to the Coolant Inlet hose (solid black). Connect the other siphon hose to the Coolant Outlet hose (with clear window).
3. Place the end of the Coolant Inlet hose (solid black) in the container of new or recycled coolant to be transferred.
4. Hold the end of the Coolant Outlet hose (with clear window) in the sink and open the valve on the Coolant Outlet hose.
5. Turn the upper control panel valve to TRANSFER. Set the control panel switch to ON.
6. When the New Coolant tank is filled to the desired level (check graduation on sight glass), close the valve on the Coolant Outlet hose (with clear window) and set the control panel switch to OFF.
7. Disconnect the siphon hoses from both the Coolant Inlet and Outlet hose, and return all hoses to their original positions.
8. Disconnect the black power lead, then disconnect the red power lead from the vehicle battery or 12V power source. Store the hoses and power leads on the side brackets.

Optional Power Fill

Emptying Procedures

EMPTYING THE USED COOLANT TANK

Use the pump to transfer the coolant from the Used Coolant tank into a suitable storage container.

⚠ WARNING! ⚠

Handle battery connection cables with extreme caution — batteries generate explosive gases during normal battery operation. Working in the vicinity of a lead-acid or other automotive battery is dangerous. Wear complete eye protection. NEVER smoke or allow a spark or flame in the vicinity of a battery.

1. Connect the power leads to the vehicle battery or to another 12V power source. The red lead goes to the "+" (positive) post first, then the black lead to an engine ground, *not* the battery "-" terminal.
2. Connect the Coolant Inlet hose (solid black) to the drain port on the bottom front of the unit. Connect a siphon hose to the Coolant Outlet hose (with clear window).
3. Secure the Coolant Outlet hose in a suitable storage container and open the valve on the Coolant Outlet hose.
4. Turn the upper control panel valve to TRANSFER and set the control panel switch to ON.
5. To stop the transfer, set the control panel switch to OFF.
6. Close the valve on the Coolant Outlet hose (with clear window) and disconnect the siphon hose assembly from the Coolant Outlet hose. Return all hoses to their original positions.
7. Disconnect the black power lead, then disconnect the red power lead from the vehicle battery or 12V power source. Store the hoses and power leads on the side brackets.

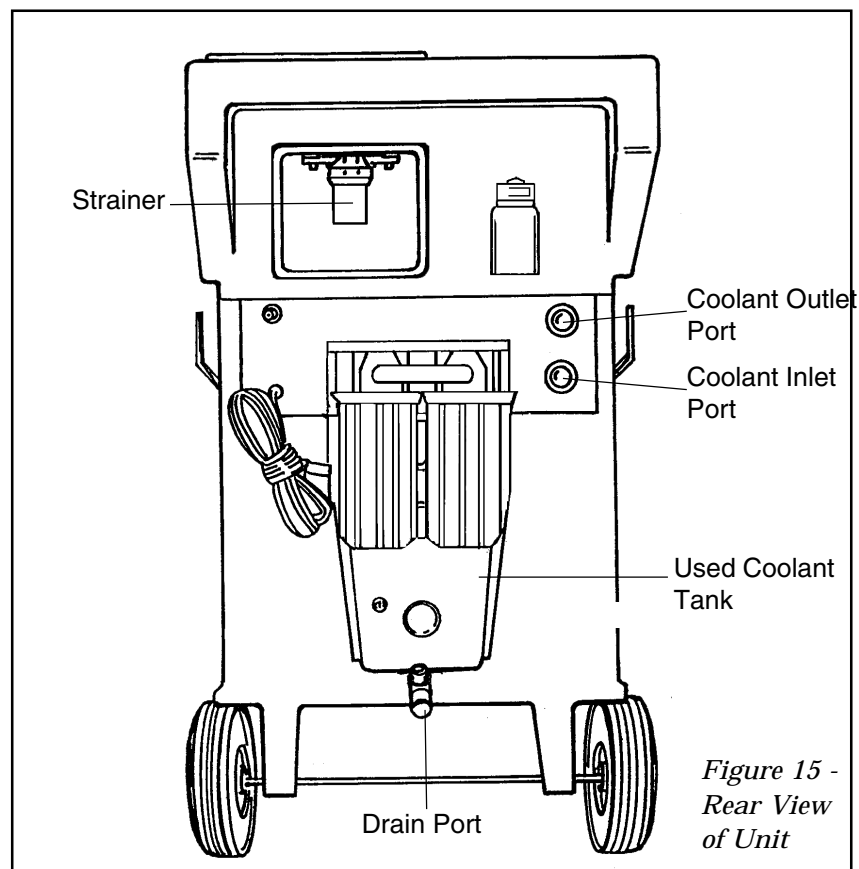

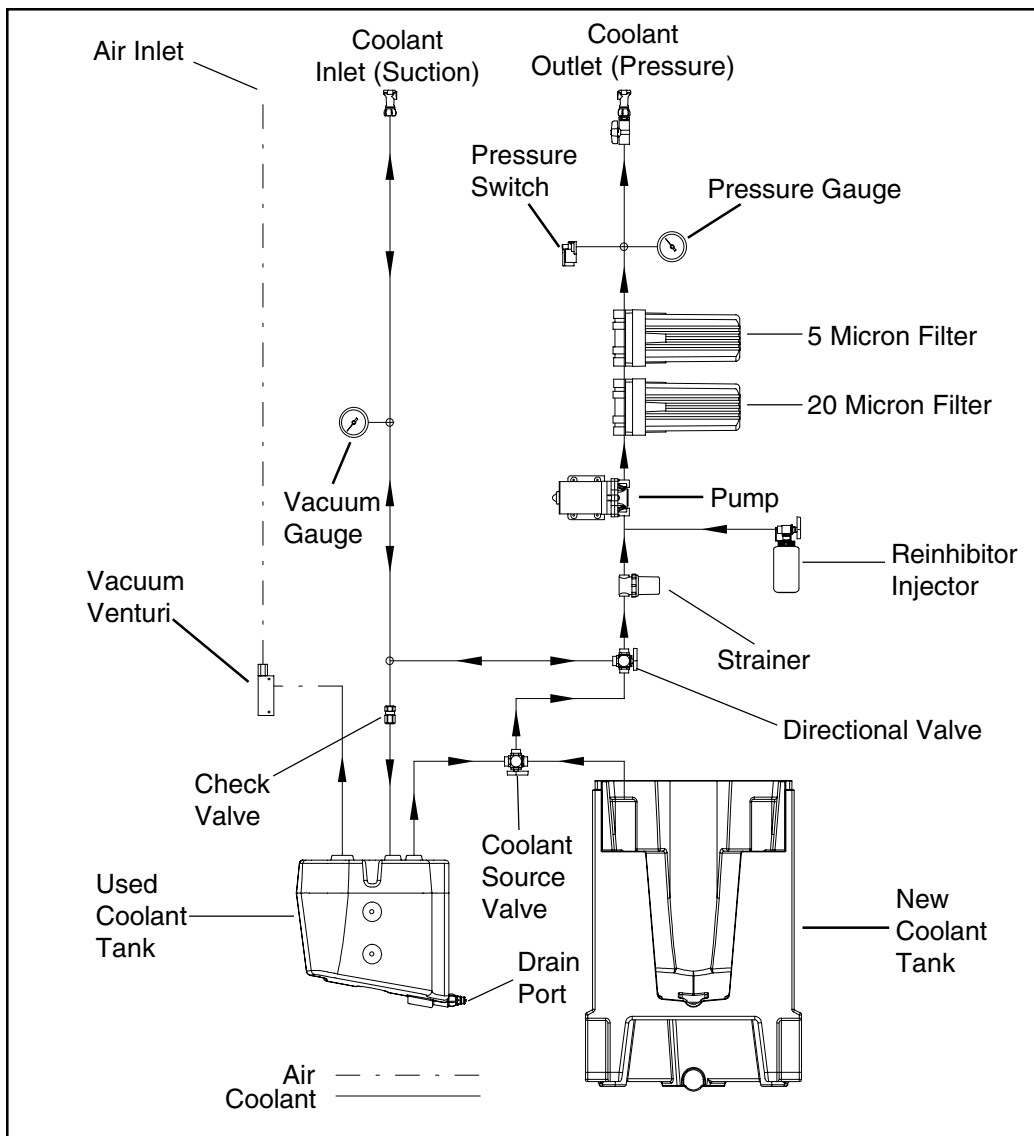

Flow Diagram

75612	1", 1¼", 1⅜", 1½" Step Adapter	RA19527	Outlet Hose Assembly
75134	Coolant Test Strips	RA19528	Inlet Hose Assembly
75251	20-Micron Filter (4 per box)	RA19529	Sight Glass
75252	5-Micron Filter (4 per box)	RA19530	Power Switch
75253	Robinair Advanced Formula Reinhibitor - North American (24 bottles per case)	RA19531	Coolant Directional Valve
75254	Robinair Advanced Formula Reinhibitor - Asian (24 bottles per case)	RA19532	Vacuum Gauge
RA19554	5/16" Siphon Hose Adapter	RA19533	Pressure Gauge
RA19553	3/8" Siphon Hose Adapter	RA19534	Float Switch
RA19541	Large Radiator Cap Assembly	RA19537	Coupling Body
RA19542	Small Radiator Cap Assembly	RA19538	Coupling Insert, Female
RA19524	Rear Tire	RA19539	Coupling Insert, Male
RA19525	Front Caster	RA19540	Strainer
RA19526	Relay		
		Optional Accessories	
		75613	1¾", 2", 2¼" Step Adapter
		75323	Refractometer

Replacement Parts List

Because of on-going product improvements, we reserve the right to change specifications, design and materials without notice.

Maintenance Instructions

There are just a few routine maintenance procedures required to keep your unit operating properly.

CLEANING THE UNIT

1. After servicing your vehicle, return all hoses and power leads to the side brackets. Replace any adapters or accessories in the storage area. This will help prevent damage to the components.
2. Regularly wipe off the unit to remove any spilled coolant, grease, dust, and other foreign materials.

CLEANING THE STRAINER

The strainer is located in the back of the unit under the handles. Check the bowl before each use and clean if any amount of debris is present.

IMPORTANT! If the strainer plugs, the drain and fill operation will not function properly and may cause engine overheating.

Follow these steps to clean the strainer:

1. Set the control panel switch to OFF and disconnect the air supply.
2. Remove the plastic bowl.

WARNING!

Wear proper protective equipment including gloves and safety goggles when removing and cleaning the strainers.

3. Remove the screen and rinse both the bowl and the screen. Be careful not to damage the screen, bowl or gasket.
4. Place the gasket and the screen in the bowl and screw the bowl back on to the body.
5. Hand tighten the bowl to the body (do **not** use pliers or wrenches).



Lined area for writing notes, consisting of multiple horizontal lines.

Notes

Limited Warranty

This product is warranted to be free from defects in workmanship, materials and components for a period of one year from date of purchase. All parts and labor required to repair defective products covered under the warranty will be at no charge.

The following restrictions apply:

1. The limited warranty applies to the original purchaser only.
2. The warranty applies to the product in normal usage situations only, as described in the Operating Manual. The product must also be serviced and maintained as specified.
3. If the product fails, it will be repaired or replaced at the option of the manufacturer.
4. Warranty service is provided by our network of authorized service centers. Call the toll-free Technical Support Line, (800) 822-5561, for service authorization and the location of the nearest service center. **Do not** ship or deliver units to a service center without authorization. **Do not** ship units to the factory.
5. Warranty service claims are subject to factory inspection for product defect(s). The factory or service center personnel are the sole determiners of warranty coverage.
6. The manufacturer shall not be responsible for any additional costs, such as loss of coolant or shop labor, associated with a product failure.
7. All warranty service claims must be made within the specified warranty period. Proof-of-purchase date must be supplied to the manufacturer.

This Limited Warranty does not apply if:

- The product or product part has been broken by accident.
- The product has been misused, tampered with, or modified.
- The product has been used for any purpose other than exchanging and testing engine coolant.



Call toll-free

Technical Support Line
800-822-5561

in the continental U.S. and Canada.

In all other locations, contact your local distributor. To help us serve you better, please be prepared to provide the model number, serial number, and date of purchase.

To validate your warranty, you must complete the warranty card attached to your unit and return it within ten days from date of purchase.

NATIONWIDE NETWORK OF AUTHORIZED SERVICE CENTERS

If your unit needs repairs or replacement parts, you should contact the service center in your area. For help in locating a service center, call the toll free technical support line, or visit our web site at **www.robinair.com**.

Additional copies of this operating manual
are available for \$5 each.

To order, call (800) 822-5561.

SPX **ROBINAIR**

*SPX Corporation
1224 Robinair Way
Montpelier, OH 43543-1952 USA
Phone (419) 485-5561
Fax (419) 485-8300*